

Filter Housing HD High Pressure

The HD high pressure filter housings are designed for the purification of compressed air and gases. Due to the modular design of the housings different filter elements can be used.

Product description:

HD high pressure housings are designed for the purification of compressed air and gases in an industrial operation. The housings made out of two parts offer, due to an optimized construction, low differential pressures at high flow rates. A multitude of housings with different connections, allow to match the requirements of the application, e. g. the compressor size.

In this product series are 8 different housings available ranging from a volume flow of 30 m³/h to 720 m³/h, in the pressure stages PN 25 to PN 400 (related to 7 bar (g) and 20°C).

The HD high pressure housings conforms to the requirements of the European directive 97/23/EC for pressure vessels.



Technical Data

Materials:	
Filter housing:	
PN25 - PN64	Aluminium EN AW 5754
PN100 - PN400	Steel C 22.8 Stainless steel on request
Sealing:	O-ring, Parting compound free, made of Perbunan

Maximum operating temperature:
-10°C / +80°C

Surface finish:	
PN25 - PN64	Aluminium anodized
PN100 - PN400	Carbon Steel electroless nickel

Pressure stages:	
PN25	PN100
PN40	PN250
PN64	PN400

Connection:
1/4" bis 2" BSP

Industrial filter HD 0003 - 0072, 25-64 bar

Pos.	Piece	Benennung
6	1	sealing
5	1	screw plug
4	1	housing O-ring
3	1	filter element
2	1	lower housing bowl
1	1	upper housing bowl

Max. operating pressure:	25 bar, 40 bar 64 bar
Test pressure:	36 bar, 57.2 bar 92 bar
Max. operating temperature:	-10°C / +80°C
Material:	EN AW 5754
Paint coat:	anodized

Classification acc. 97 / 23 / EG for fluids group 2	
HD 0003 - 0036 HD 0048 25 bar	Art. 3, par. 3
HD 0048 40-64 bar HD 0072 25-64 bar	Cat. I

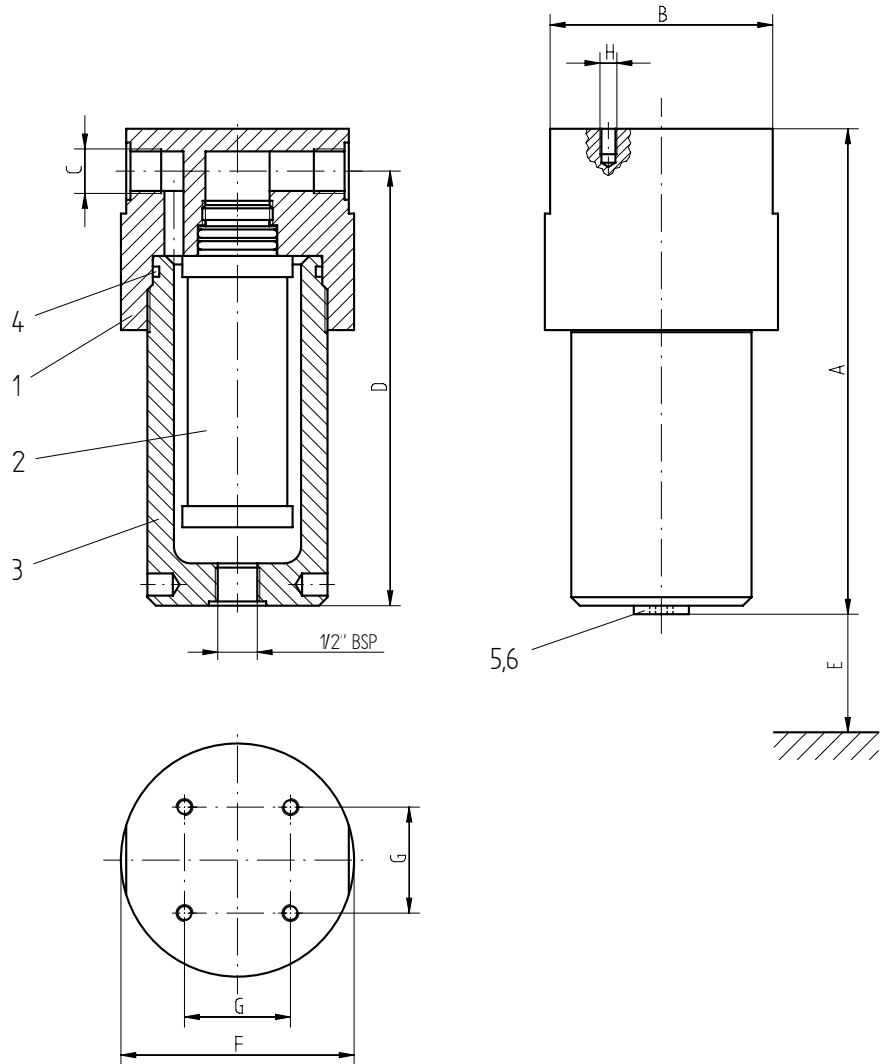

Housing size	Volume (l)	Weight* (kg)	A mm	B mm	C	D mm	E mm	F ø mm	G mm	H	Element size
0003	0.20	1.6	165	85	G 1/4	145	130	90	50	4xM8	03/05
0006	0.20	1.6	165	85	G 3/8	145	130	90	50	4xM8	03/10
0012	0.42	2.6	205	105	G 1/2	185	190	110	50	4xM8	04/20
0018	0.49	2.8	230	105	G 3/4	205	190	110	50	4xM8	05/20
0027	0.66	4.3	235	119	G 1	210	190	130	70	4xM10	05/25
0036	0.90	4.6	290	119	G 1 1/4	255	250	130	70	4xM10	07/25
0048	1.72	7.4	315	150	G 1 1/2	280	250	160	80	4xM10	07/30
0072	3.02	18.9	405	186	G 2	365	340	200	110	4xM12	10/30

* without filter element

Industrial filter HD 0003 - 0072, 100-400 bar

Pos.	Piece	Benennung
6	1	sealing
5	1	screw plug
4	1	housing O-ring
3	1	filter element
2	1	lower housing bowl
1	1	upper housing bowl

Max. operating overpressure:	100 bar, 250 bar 400 bar
Test pressure:	143 bar, 357.5 bar 572 bar
Max. operating temperature:	-10°C / +80°C
Material:	C22.8 with 3.1B certificate acc. to EN 10204
Paint coat:	electroless nickel

Classification acc. to 97 / 23 / EC for fluids group 2	
HD 0003 - 0036	Art. 3, par. 3
HD 0048 100 bar	Cat. I
HD 0048 250-400 bar HD 0072 100-250 bar	Cat. II
HD 0072 400 bar	Cat. III

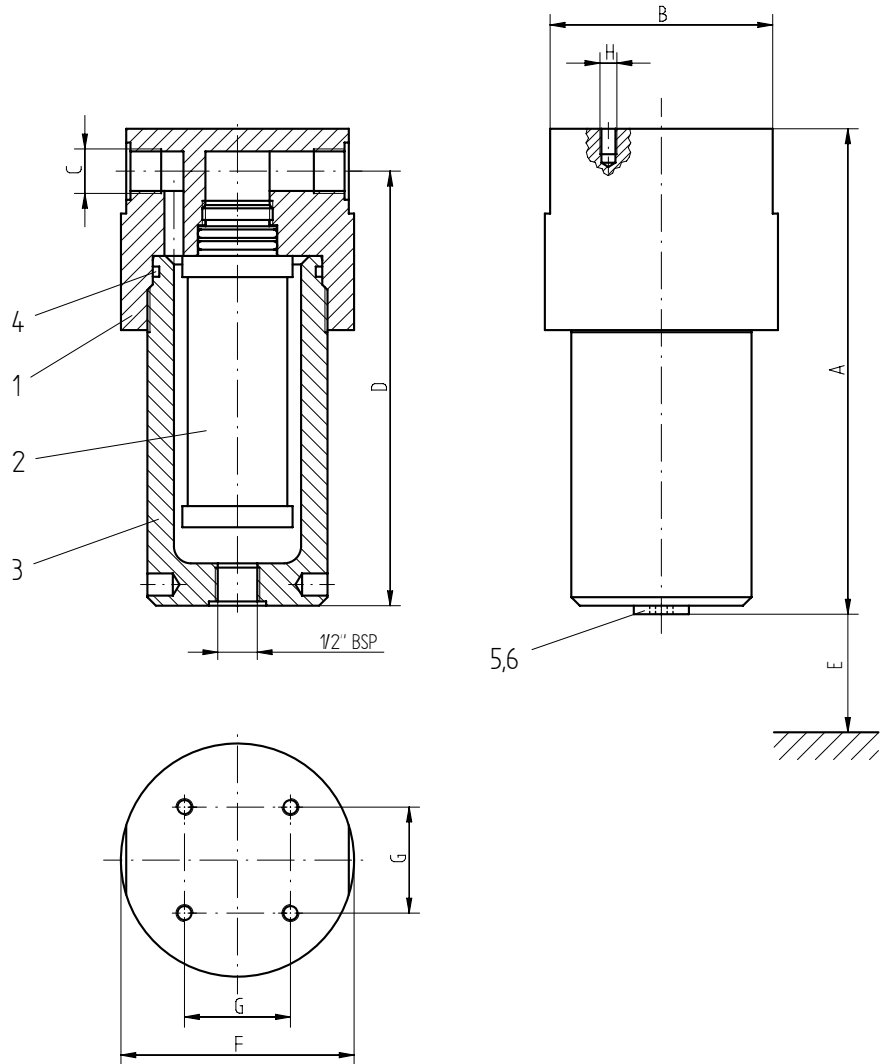

Housing size	Volume (l)	Weight* (kg)	A mm	B mm	C	D mm	E mm	F mm	G mm	H	Element size
0003	0.20	5	170	85	G 1/4	150	130	90	50	4xM8	03/05
0006	0.20	5	170	85	G 3/8	150	130	90	50	4xM8	03/10
0012	0.42	9	210	105	G 1/2	190	190	110	50	4xM8	04/20
0018	0.49	9.5	235	105	G 3/4	215	190	110	50	4xM8	05/20
0027	0.66	14.5	250	119	G 1	220	190	130	70	4xM10	05/25
0036	0.90	16	305	119	G 1 1/4	270	250	130	70	4xM10	07/25
0048	1.72	27.5	330	150	1 1/2	295	250	160	80	4xM10	07/30
0072	3.02	60	420	186	G 2	380	340	200	110	4xM12	10/30

* without filter element